

## Air Regulator

### Features

- ▶ Zinc Pressure Die Cast Standard Grade with Powder Coated Body
- ▶ Comfortable to all industrial use
- ▶ Mounting Available
- ▶ Heavy Design & Rugged Use
- ▶ Lockable Rotary Knob

### Technical Specification

Model	F01 - R	F02 - R
Size	1/4"	1/2"
Pressure	Upto 16 BAR	
Temperature	Upto 60 °C	
Leakage	Bubble Tight	
Media	Compressed air	

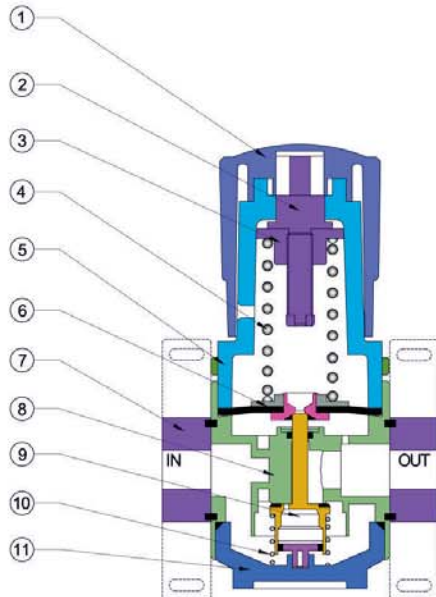

No.	Part Name	Material
1	Knob	Nylon
2	Adjusting Stud	Steel Plated
3	Nut	Steel Plated
4	Adjusting Spring	Spring Steel
5	Bonnet	Nylon
6	Diaphragm	NBR
7	Side Connector	Zinc Pressure Die Cast
8	Body	Zinc Pressure Die Cast
9	Plunger	Brass
10	Bottom Spring	S. Steel
11	Bottom Plug	Aluminum Pressure Die Cast

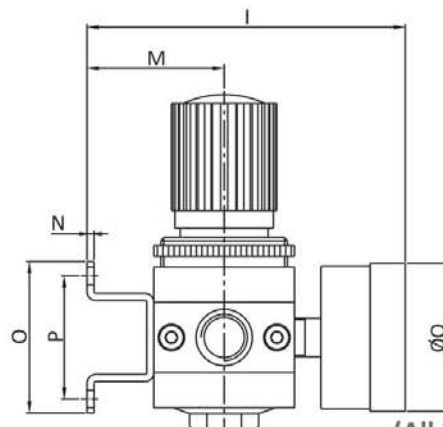
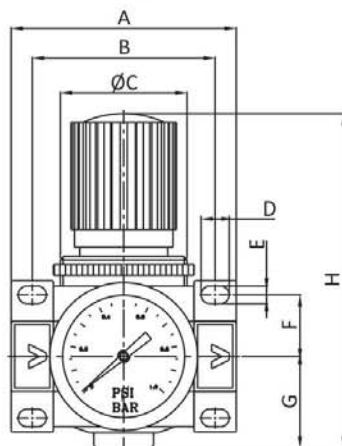

### Dimensions :

(All Dimensions are in mm)

MODEL	SIZE	A	B	ØC	D	E	F	G	H	I	M	N	O	P	ØQ	Weight (Kg.) Approx.
F01 - R	1/4"	64	52	36	8	5	17.5	26	95	90.5	39	2	43	35	42	0.487
F02 - R	1/2"	85	70	52	8.5	5.5	30	34.5	137	110	47	3	70	60	52	1.128